

REV	ECO	REV BY	DATE	APPD	DATE
W	0025426	C.ZHANG	04-18-2012	B.SHEN	04-18-2012

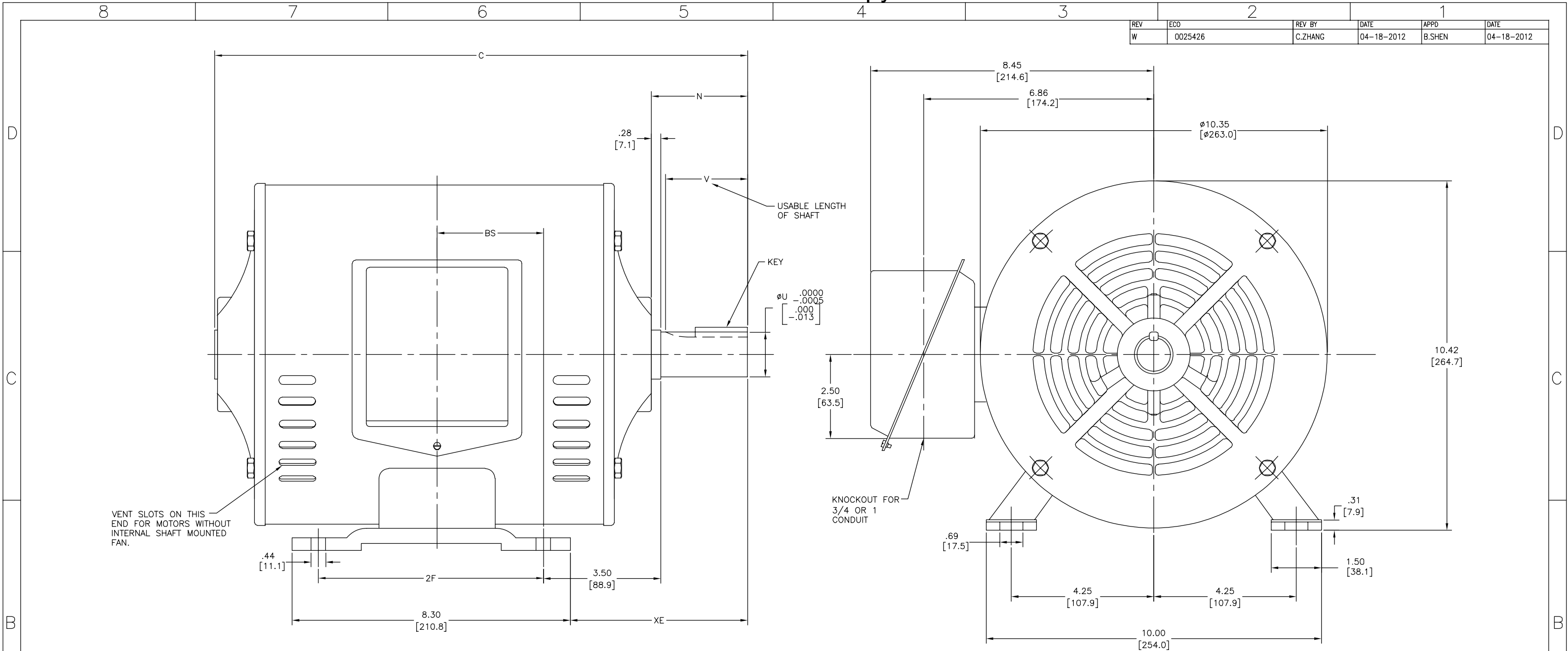

FRAME	FORM	KEY			MOTORS DIMENSIONS						
		WIDTH	DEPTH	LENGTH	C	N	U	V	2F	BS	XE
D213T	S	.313[7.95]	.156[3.96]	2.38[60.4]	16.57[420.8]	3.66[92.9]	1.375[34.92]	3.13[79.5]	5.50[139.7]	3.39[86.1]	6.25[158.7]
E213T	S	.313[7.95]	.156[3.96]	2.38[60.4]	17.07[433.5]	3.66[92.9]	1.375[34.92]	3.13[79.5]	5.50[139.7]	3.64[92.4]	6.25[158.7]
H213T	S	.313[7.95]	.156[3.96]	2.38[60.4]	17.57[446.2]	3.66[92.9]	1.375[34.92]	3.13[79.5]	5.50[139.7]	3.89[98.8]	6.25[158.7]
M213T	S	.313[7.95]	.156[3.96]	2.38[60.4]	18.07[458.9]	3.66[92.9]	1.375[34.92]	3.13[79.5]	5.50[139.7]	4.14[105.1]	6.25[158.7]
S213	S	.250[6.35]	.125[3.17]	2.00[50.8]	15.18[385.5]	3.28[83.3]	1.125[28.57]	2.75[69.8]	5.50[139.7]	2.89[73.4]	5.86[148.8]
S213T	S	.313[7.95]	.156[3.96]	2.38[60.4]	15.57[395.4]	3.66[92.9]	1.375[34.92]	3.13[79.5]	5.50[139.7]	2.89[73.4]	6.25[158.7]
Y213T	S	.313[7.95]	.156[3.96]	2.38[60.4]	18.30[464.8]	3.66[92.9]	1.375[34.92]	3.13[79.5]	5.50[139.7]	4.26[108.2]	6.25[158.7]
D215T	S	.313[7.95]	.156[3.96]	2.38[60.4]	16.57[420.8]	3.66[92.9]	1.375[34.92]	3.13[79.5]	7.00[177.8]	3.39[86.1]	6.25[158.7]
E215T	S	.313[7.95]	.156[3.96]	2.38[60.4]	17.07[433.5]	3.66[92.9]	1.375[34.92]	3.13[79.5]	7.00[177.8]	3.64[92.4]	6.25[158.7]
EY215T	S	.313[7.95]	.156[3.96]	2.38[60.4]	18.55[471.1]	3.66[92.9]	1.375[34.92]	3.13[79.5]	7.00[177.8]	4.39[111.5]	6.25[158.7]
H215T	S	.313[7.95]	.156[3.96]	2.38[60.4]	17.57[446.2]	3.66[92.9]	1.375[34.92]	3.13[79.5]	7.00[177.8]	3.89[98.8]	6.25[158.7]
M215T	S	.313[7.95]	.156[3.96]	2.38[60.4]	18.07[458.9]	3.66[92.9]	1.375[34.92]	3.13[79.5]	7.00[177.8]	4.14[105.1]	6.25[158.7]
S215T	S	.313[7.95]	.156[3.96]	2.38[60.4]	15.57[395.4]	3.66[92.9]	1.375[34.92]	3.13[79.5]	7.00[177.8]	2.89[73.4]	6.25[158.7]
S215	S	.250[6.35]	.125[3.17]	2.00[50.8]	15.57[395.4]	3.28[83.3]	1.125[28.57]	2.75[69.8]	7.00[177.8]	2.89[73.4]	5.86[148.8]
Y215T	S	.313[7.95]	.156[3.96]	2.38[60.4]	18.30[464.8]	3.66[92.9]	1.375[34.92]	3.13[79.5]	7.00[177.8]	4.26[108.2]	6.25[158.7]

NOTES:

- UNITS CANNOT BE CONVERTED FROM F1 TO F2 ASSEMBLY.
- MULTI-SPEED MOTORS HAVE A KNOCKOUT FOR 1-1/4 CONDUIT.
- SHAFT RUNOUT .002[0.05].

GEOMETRIC CHARACTERISTICS & SYMBOLS ▽ FLATNESS — STRAIGHTNESS ∠ ANGULARITY ⊥ PERPENDICULARITY (SQUARENESS) // PARALLELISM ○ ROUNDNESS (CIRCULARITY) Ⓞ CYLINDRICITY ≡ PROFILE OF ANY SURFACE ⤴ PROFILE OF ANY LINE ↗ RUNOUT ⊕ TRUE POSITION ⊙ CONCENTRICITY = SYMMETRY	UNLESS OTHERWISE SPECIFIED DIM. TOLERANCES ARE AS FOLLOWS: INCH .1 ±.02 ±.005 ±.0005 mm .005 ±0.13 ±0.013 ANG. ±.50 DEG REMOVE BURRS & BREAK SHARP EDGES: INCH .003-.015 mm 0.1-0.4 CORNER FILLETS TO: INCH .020 mm 0.5 MACHINE SURFACES: INCH 125 mm 3.2 METRIC DIMS. SHOWN IN [BRACKETS]	DR BY: H.Sanchez	12-13-2008	REGAL-BELOIT CORPORATION REGAL-BELOIT CORPORATION CONFIDENTIAL: THIS DRAWING AND ITS INFORMATION ARE THE EXCLUSIVE AND CONFIDENTIAL PROPERTY OF REGAL-BELOIT CORPORATION AND ARE NOT TO BE DISCLOSED, DUPLICATED, DISTRIBUTED OR OTHERWISE USED WITHOUT THE WRITTEN CONSENT OF REGAL-BELOIT CORPORATION. -ALL RIGHTS RESERVED.
		APPD: JCLW	05-05-1995	
		THRD ANGLE PROJECTION	FORMAT REV G	SIZE D DWG NO 114542
				SCALE NONE SHEET 1

版本	ECO	编制	日期	批准	日期
W	0025426	C.ZHANG	04-18-2012	B.SHEN	04-18-2012

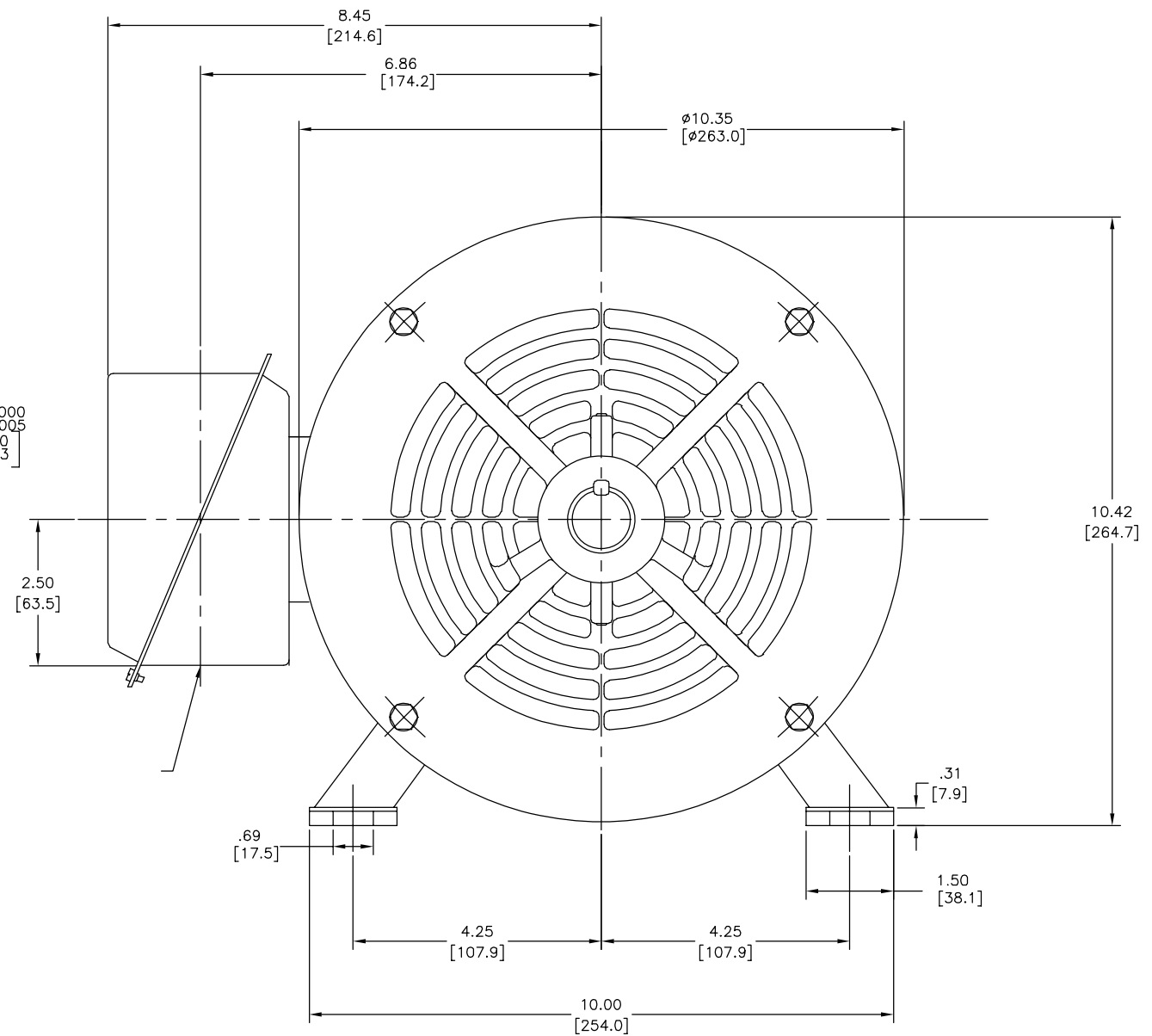
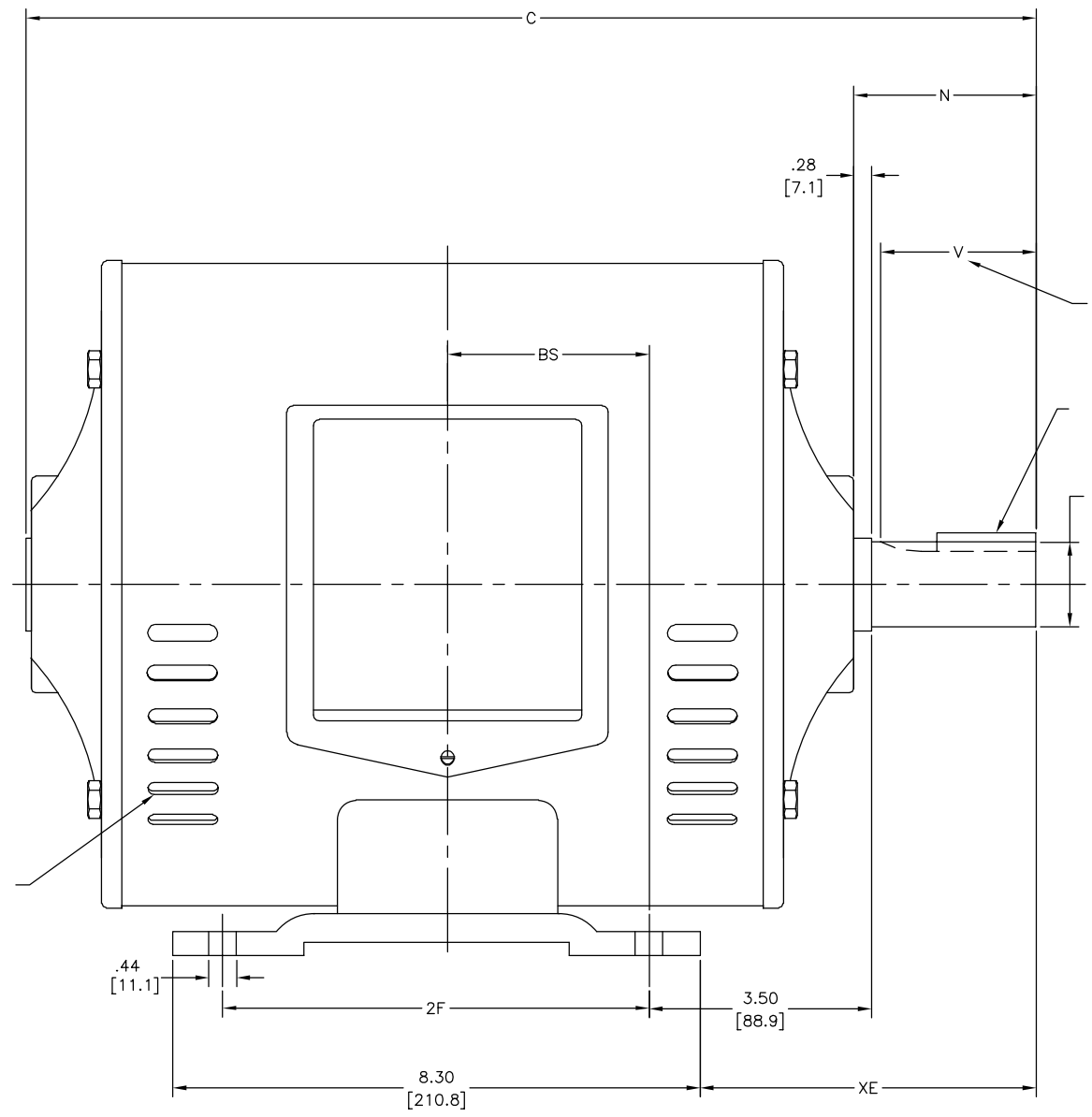

	FORM											
D213T	S	.313[7.95]	.156[3.96]	2.38[60.4]	16.57[420.8]	3.66[92.9]	1.375[34.92]	3.13[79.5]	5.50[139.7]	3.39[86.1]	6.25[158.7]	
E213T	S	.313[7.95]	.156[3.96]	2.38[60.4]	17.07[433.5]	3.66[92.9]	1.375[34.92]	3.13[79.5]	5.50[139.7]	3.64[92.4]	6.25[158.7]	
H213T	S	.313[7.95]	.156[3.96]	2.38[60.4]	17.57[446.2]	3.66[92.9]	1.375[34.92]	3.13[79.5]	5.50[139.7]	3.89[98.8]	6.25[158.7]	
M213T	S	.313[7.95]	.156[3.96]	2.38[60.4]	18.07[458.9]	3.66[92.9]	1.375[34.92]	3.13[79.5]	5.50[139.7]	4.14[105.1]	6.25[158.7]	
S213	S	.250[6.35]	.125[3.17]	2.00[50.8]	15.18[385.5]	3.28[83.3]	1.125[28.57]	2.75[69.8]	5.50[139.7]	2.89[73.4]	5.86[148.8]	
S213T	S	.313[7.95]	.156[3.96]	2.38[60.4]	15.57[395.4]	3.66[92.9]	1.375[34.92]	3.13[79.5]	5.50[139.7]	2.89[73.4]	6.25[158.7]	
Y213T	S	.313[7.95]	.156[3.96]	2.38[60.4]	18.30[464.8]	3.66[92.9]	1.375[34.92]	3.13[79.5]	5.50[139.7]	4.26[108.2]	6.25[158.7]	
D215T	S	.313[7.95]	.156[3.96]	2.38[60.4]	16.57[420.8]	3.66[92.9]	1.375[34.92]	3.13[79.5]	7.00[177.8]	3.39[86.1]	6.25[158.7]	
E215T	S	.313[7.95]	.156[3.96]	2.38[60.4]	17.07[433.5]	3.66[92.9]	1.375[34.92]	3.13[79.5]	7.00[177.8]	3.64[92.4]	6.25[158.7]	
EY215T	S	.313[7.95]	.156[3.96]	2.38[60.4]	18.55[471.1]	3.66[92.9]	1.375[34.92]	3.13[79.5]	7.00[177.8]	4.39[111.5]	6.25[158.7]	
H215T	S	.313[7.95]	.156[3.96]	2.38[60.4]	17.57[446.2]	3.66[92.9]	1.375[34.92]	3.13[79.5]	7.00[177.8]	3.89[98.8]	6.25[158.7]	
M215T	S	.313[7.95]	.156[3.96]	2.38[60.4]	18.07[458.9]	3.66[92.9]	1.375[34.92]	3.13[79.5]	7.00[177.8]	4.14[105.1]	6.25[158.7]	
S215T	S	.313[7.95]	.156[3.96]	2.38[60.4]	15.57[395.4]	3.66[92.9]	1.375[34.92]	3.13[79.5]	7.00[177.8]	2.89[73.4]	6.25[158.7]	
S215	S	.250[6.35]	.125[3.17]	2.00[50.8]	15.57[395.4]	3.28[83.3]	1.125[28.57]	2.75[69.8]	7.00[177.8]	2.89[73.4]	5.86[148.8]	
Y215T	S	.313[7.95]	.156[3.96]	2.38[60.4]	18.30[464.8]	3.66[92.9]	1.375[34.92]	3.13[79.5]	7.00[177.8]	4.26[108.2]	6.25[158.7]	

形位公差
 平面度
 直线度
 倾斜度
 垂直度
 平行度
 圆度
 圆柱度
 面轮廓度
 线轮廓度
 圆跳动
 位置度
 同轴度
 对称度

除另有注明
 尺寸公差如下:
 英寸 X XX XXX XXXX
 毫米 ±.1 ±.02 ±.005 ±.0005
 毫米 ±0.5 ±0.13 ±0.013
 角度 ±.50 度
 清理毛刺和尖棱
 英寸 .003-.015 毫米 0.1-0.4
 内圆角
 英寸 .020 毫米 0.5
 表面粗糙度
 英寸 125 米制 3.2
 米制尺寸显示在 []

ASME Y14.5M 1994

绘图: H.Sanchez 12-13-2008
 批准: JCLW 05-05-1995
 第三角投影
 图框格式发布日期 11-11-2011
 图框格式版本 G

名称: OUTLINE
 图号: 114542
 比例: NONE
 页号: 1

REGAL-BELOIT CORPORATION
 机密: 本图纸及相关信息所有权归REGAL-BELOIT CORPORATION
 未经REGAL-BELOIT CORPORATION书面授权, 不得泄露、
 复制、传播或作其他用途。—版权所有